

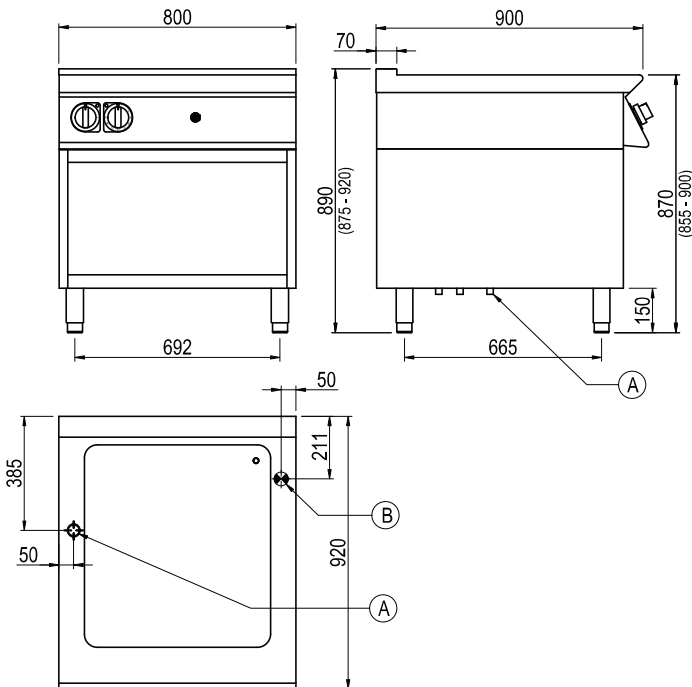

Product Information:

- Class leading, European style, professional quality and reliability since 1963
- 900 series, electric 2/1 + 2 x 1/3 GN Bain Marie (3.6kW)
- Silicone heating pad external to the tank provides uniform heating, superior hygiene and ease of cleaning
- Temperature regulation via thermostat (30°C - 90°C)
- Indicator lights to monitor the correct operation of the appliance
- Manual water fill with tank sloped to solenoid valve operated drain
- Robust 304 grade stainless steel construction with rounded corners for improved cleaning
- Open base with optional doors available (SPGI.2016437)
- Height adjustable stainless steel feet for a 900mm working height
- 24-month warranty

General Drawing:



Specifications:

Model	BM940ET
W x D x H (mm)	800 x 920 x 890
Weight	120kg
Capacity	1 x 2/1 + 2 x 1/3 150mm GN Pans
Packed Dimensions (mm)	940 x 960 x 1215
Packed Weight	132kg
Electrical Connection	1Ø + N + E 240VAC / 50Hz / 3.6kW 15A plug & lead fitted

Legend:

- A Electrical Connection
- B Drain Connection 1/2" BSP